

AP PHYSICS E&M: RELEASED EXAM 2004 MULTIPLE CHOICE

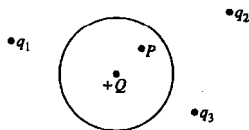

36. Three  $1/2 \mu\text{F}$  capacitors are connected in series as shown in the diagram above. The capacitance of the combination is (A)  $0.1 \mu\text{F}$  (B)  $1 \mu\text{F}$  (C)  $2/3 \mu\text{F}$  (D)  $1/2 \mu\text{F}$  (E)  $1/6 \mu\text{F}$
37. A hair dryer is rated as 1200 W, 120 V. Its effective internal resistance is (A)  $0.1 \Omega$  (B)  $10 \Omega$  (C)  $12 \Omega$  (D)  $120 \Omega$  (E)  $1440 \Omega$



38. A point charge  $+Q$  is inside an uncharged conducting spherical shell that in turn is near several isolated point charges, as shown above. The electric field at point P inside the shell depends on the magnitude of (A)  $Q$  only (B) the charge distribution on the sphere only (C)  $Q$  and the charge distribution on the sphere (D) all of the point charges (E) all of the point charges and the charge distribution on the sphere
39. In a certain region, the electric field along the x-axis is given by  
 $E = ax + b$ , where  $a = 40 \text{ V/m}^2$   
 and  $b = 4 \text{ V/m}$ .  
 The potential difference between the origin and  $x = 0.5 \text{ m}$  is (A)  $-36 \text{ V}$  (B)  $-7 \text{ V}$  (C)  $-3 \text{ V}$  (D)  $10 \text{ V}$  (E)  $16 \text{ V}$

Questions 40-41

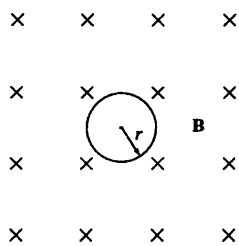

A particle of charge  $+e$  and mass  $m$  moves with speed  $v$  perpendicular to a uniform magnetic field  $\mathbf{B}$  directed into the page. The path of the particle is a circle of radius  $r$ , as shown above.

40. Which of the following correctly gives the direction of motion and the equation relating  $v$  and  $r$ ?
- | Direction            | Equation       |
|----------------------|----------------|
| (A) Clockwise        | $eBr = mv$     |
| (B) Clockwise        | $eBr = mv^2$   |
| (C) Counterclockwise | $eBr = mv$     |
| (D) Counterclockwise | $eBr = mv^2$   |
| (E) Counterclockwise | $eBr^2 = mv^2$ |

41. The period of revolution of the particle is (A)  $m/eB$  (B)  $\sqrt{m/eB}$  (C)  $2\pi m/eB$  (D)  $2\pi\sqrt{m/eB}$  (E)  $2\pi\sqrt{mr/eB}$

42. A  $20 \mu\text{F}$  parallel-plate capacitor is fully charged to 30 V. The energy stored in the capacitor is most nearly (A)  $9 \times 10^3 \text{ J}$  (B)  $9 \times 10^{-3} \text{ J}$  (C)  $6 \times 10^{-4} \text{ J}$  (D)  $2 \times 10^{-4} \text{ J}$  (E)  $2 \times 10^{-7} \text{ J}$

43. A potential difference  $V$  is maintained between two large, parallel conducting plates. An electron starts from rest on the surface of one plate and accelerates toward the other. Its speed as it reaches the second plate is proportional to (A)  $1/V$  (B)  $1/\sqrt{V}$  (C)  $\sqrt{V}$  (D)  $V$  (E)  $V^2$

44. A wire of radius  $R$  has a current  $I$  uniformly distributed across its cross-sectional area. Ampere's law is used with a concentric circular path of radius  $r$ , with  $r < R$ , to calculate the magnitude of the magnetic field  $B$  at a distance  $r$  from the center of the wire. Which of the following equations results from a correct application of Ampere's law to this situation? (A)  $B(2\pi r) = \mu_0 I$  (B)  $B(2\pi r) = \mu_0 I(r^2/R^2)$  (C)  $B(2\pi r) = 0$  (D)  $B(2\pi R) = \mu_0 I$  (E)  $B(2\pi R) = \mu_0 I(r^2/R^2)$

Questions 45-46

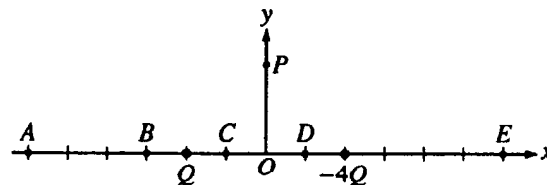

Particles of charge  $Q$  and  $-4Q$  are located on the x-axis as shown in the figure above. Assume the particles are isolated from all other charges.

45. Which of the following describes the direction of the electric field at point P? (A)  $+x$  (B)  $+y$  (C)  $-y$  (D) Components in both the  $-x$ - and  $+y$ -directions (E) Components in both the  $+x$ - and  $-y$ -directions
46. At which of the labeled points on the x-axis is the electric field zero? (A) A (B) B (C) C (D) D (E) E

AP PHYSICS E&M: RELEASED EXAM 2004 MULTIPLE CHOICE

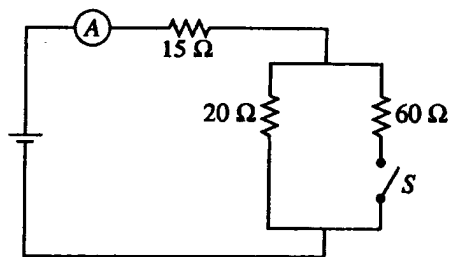

47. When the switch  $S$  is open in the circuit shown above, the reading on the ammeter  $A$  is  $2.0$  A. When the switch is closed, the reading on the ammeter is
- (A) doubled  
 (B) increased slightly but not doubled  
 (C) the same  
 (D) decreased slightly but not halved  
 (E) halved

48. Two conducting cylindrical wires are made out of the same material. Wire  $X$  has twice the length and twice the diameter of wire  $Y$ . What is the ratio  $R_X/R_Y$  of their resistances?
- (A)  $1/4$  (B)  $1/2$  (C)  $1$  (D)  $2$  (E)  $4$

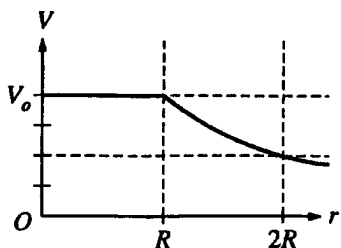

49. A solid metallic sphere of radius  $R$  has charge  $Q$  uniformly distributed on its outer surface. A graph of electric potential  $V$  as a function of position  $r$  is shown above. Which of the following graphs best represents the magnitude of the electric field  $E$  as a function of position  $r$  for this sphere?

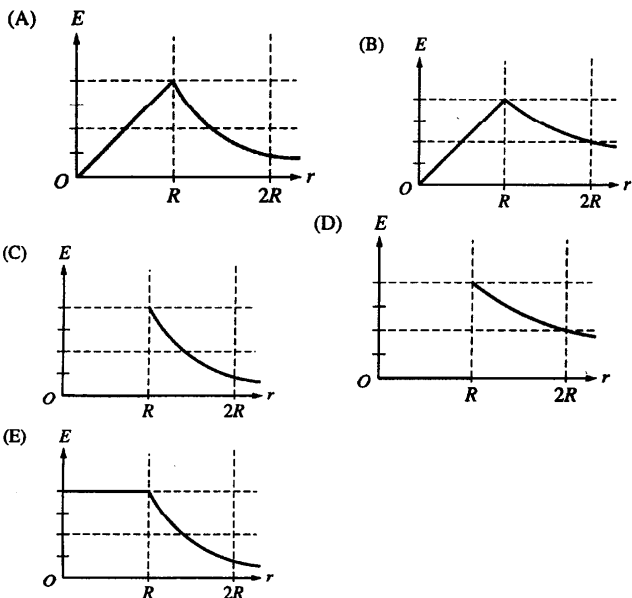

50. Two parallel wires, each carrying a current  $I$ , repel each other with a force  $F$ . If both currents are doubled, the force of repulsion is
- (A)  $2F$  (B)  $2\sqrt{2}F$  (C)  $4F$   
 (D)  $4\sqrt{2}F$  (E)  $8F$

51. A circular current-carrying loop lies so that the plane of the loop is perpendicular to a constant magnetic field of strength  $B$ . Suppose that the radius  $R$  of the loop could be made to increase with time  $t$  so that  $R = at$ , where  $a$  is a constant. What is the magnitude of the emf that would be generated around the loop as a function of  $t$ ?
- (A)  $2\pi Ba^2t$  (B)  $2\pi Bat$  (C)  $2\pi Bt$   
 (D)  $\pi Ba^2t$  (E)  $(\pi/3)Ba^2t^3$

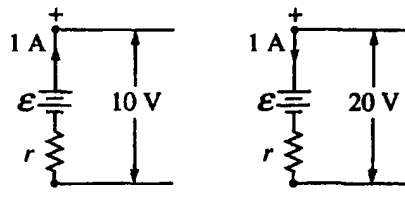

52. The figures above show parts of two circuits, each containing a battery of emf  $\mathcal{E}$  and internal resistance  $r$ . The current in each battery is  $1$  A, but the direction of the current in one battery is opposite to that in the other. If the potential differences across the batteries' terminals are  $10$  V and  $20$  V as shown, what are the values of  $\mathcal{E}$  and  $r$ ?
- (A)  $\mathcal{E} = 5$  V,  $r = 15$   $\Omega$   
 (B)  $\mathcal{E} = 10$  V,  $r = 100$   $\Omega$   
 (C)  $\mathcal{E} = 15$  V,  $r = 5$   $\Omega$   
 (D)  $\mathcal{E} = 20$  V,  $r = 10$   $\Omega$   
 (E) The values cannot be computed unless the complete circuits are shown.

53. A charged particle can move with constant velocity through a region containing both an electric field and a magnetic field only if the
- (A) electric field is parallel to the magnetic field  
 (B) electric field is perpendicular to the magnetic field  
 (C) electric field is parallel to the velocity vector  
 (D) magnetic field is parallel to the velocity vector  
 (E) magnetic field is perpendicular to the velocity vector

AP PHYSICS E&M: RELEASED EXAM 2004 MULTIPLE CHOICE

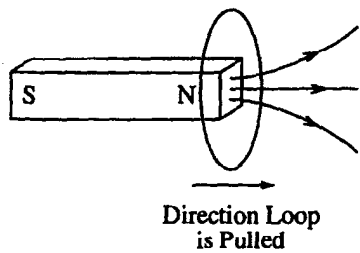

54. A conducting loop of wire that is initially around a magnet is pulled away from the magnet to the right, as indicated in the figure above, inducing a current in the loop. What is the direction of the force on the magnet and the direction of the magnetic field at the center of the loop due to the induced current?

Direction of Force on the Magnet	Direction of Magnetic Field at Center of Loop due to Induced Current
(A) To the right	To the right
(B) To the right	To the left
(C) To the left	To the right
(D) To the left	To the left
(E) No direction; the force is zero.	To the left

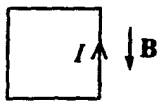

55. A square loop of wire carrying a current  $I$  is initially in the plane of the page and is located in a uniform magnetic field  $B$  that points toward the bottom of the page, as shown above. Which of the following shows the correct initial rotation of the loop due to the force exerted on it by the magnetic field?

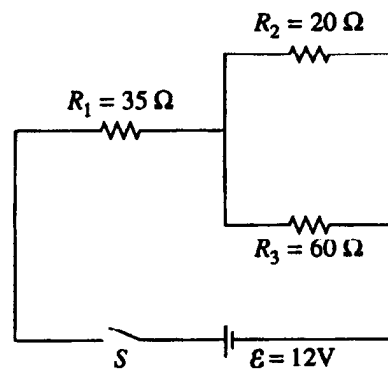
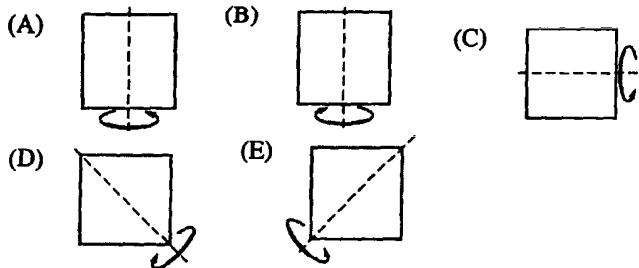

56. In the circuit shown above, the equivalent resistance of the three resistors is  
 (A)  $10.5 \Omega$  (B)  $15 \Omega$  (C)  $20 \Omega$   
 (D)  $50 \Omega$  (E)  $115 \Omega$

Questions 57-58

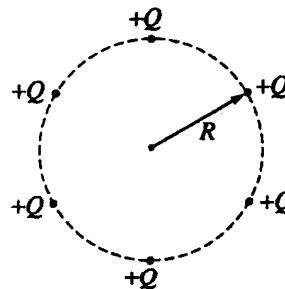

As shown in the figure above, six particles, each with charge  $+Q$ , are held fixed and are equally spaced around the circumference of a circle of radius  $R$ .

57. What is the magnitude of the resultant electric field at the center of the circle?

(A) 0 (B)  $\frac{\sqrt{6}}{4\pi\epsilon_0} \frac{Q}{R^2}$  (C)  $\frac{2\sqrt{3}}{4\pi\epsilon_0} \frac{Q}{R^2}$   
 (D)  $\frac{3\sqrt{2}}{4\pi\epsilon_0} \frac{Q}{R^2}$  (E)  $\frac{3}{2\pi\epsilon_0} \frac{Q}{R^2}$

58. With the six particles held fixed, how much work would be required to bring a seventh particle of charge  $+Q$  from very far away and place it at the center of the circle?

(A) 0 (B)  $\frac{\sqrt{6}}{4\pi\epsilon_0} \frac{Q}{R}$  (C)  $\frac{3}{2\pi\epsilon_0} \frac{Q^2}{R^2}$   
 (D)  $\frac{3}{2\pi\epsilon_0} \frac{Q^2}{R}$  (E)  $\frac{9}{\pi\epsilon_0} \frac{Q^2}{R}$

AP PHYSICS E&M: RELEASED EXAM 2004 MULTIPLE CHOICE

Questions 59-61

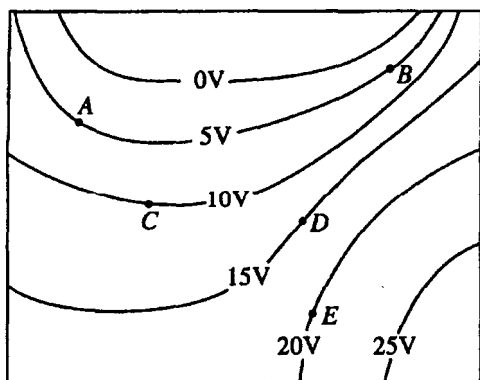

The diagram above shows equipotential lines produced by an unknown charge distribution. A, B, C, D, and E are points in the plane.

59. Which vector below best describes the direction of the electric field at point A?

- (A) (B)   
 (C) (D)

(E) None of these; the field is zero.

60. At which point does the electric field have the greatest magnitude?

- (A) A (B) B  
 (C) C (D) D  
 (E) E

61. How much net work must be done by an external force to move a  $-1 \mu\text{C}$  point charge from rest at point C to rest at point E?

- (A)  $-20 \mu\text{J}$  (B)  $-10 \mu\text{J}$   
 (C)  $10 \mu\text{J}$  (D)  $20 \mu\text{J}$  (E)  $30 \mu\text{J}$

62. One of Maxwell's equations can be written

as  $\oint \mathbf{E} \cdot d\mathbf{s} = -\frac{d\phi}{dt}$ . This equation expresses the fact that

- (A) a changing magnetic field produces an electric field  
 (B) a changing electric field produces a magnetic field  
 (C) the net magnetic flux through a closed surface depends on the current inside  
 (D) the net electric flux through a closed surface depends on the charge inside  
 (E) electric charge is conserved

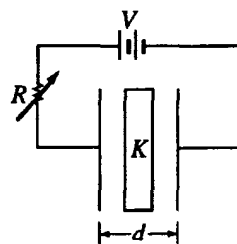

63. The plates of a parallel-plate capacitor of cross-sectional area  $A$  are separated by a distance  $d$ , as shown above. Between the plates is a dielectric material of constant  $K$ . The plates are connected in series with a variable resistance  $R$  and a power supply of potential difference  $V$ . The capacitance  $C$  of this capacitor will increase if which of the following is decreased?

- (A)  $A$  (B)  $R$  (C)  $K$   
 (D)  $d$  (E)  $V$

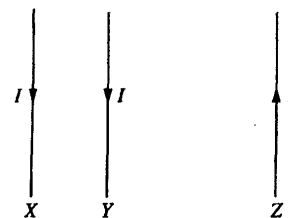

64. The currents in three parallel wires, X, Y, and Z, each have magnitude  $I$  and are in the directions shown above. Wire Y is closer to wire X than to wire Z. The magnetic force on wire Y is

(A) zero (B) into the page (C) out of the page  
 (D) toward the bottom of the page (E) toward the left

65. A physics problem starts: "A solid sphere has charge distributed uniformly throughout. . ." It may be correctly concluded that the

(A) electric field is zero everywhere inside the sphere  
 (B) electric field inside the sphere is the same as the electric field outside  
 (C) electric potential on the surface of the sphere is not constant  
 (D) electric potential in the center of the sphere is zero  
 (E) sphere is not made of metal

AP PHYSICS E&M: RELEASED EXAM 2004 MULTIPLE CHOICE

Questions 66-67 relate to the circuit represented below. The switch S, after being open for a long time, is then closed.

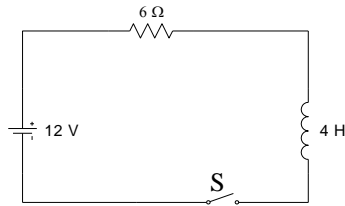

66. What is the current in the circuit after the switch has been closed a long time?  
 (A) 0 A (B) 1.2 A (C) 2 A (D) 3 A (E) 12 A
67. What is the potential difference across the resistor immediately after the switch is closed?  
 (A) 0 V (B) 2 V (C) 7.2 V (D) 8 V (E) 12 V
68. A uniform spherical charge distribution has radius  $R$ . Which of the following is true of the electric field strength due to this charge distribution at a distance  $r$  from the center of the charge?  
 (A) It is greatest when  $r = 0$ .  
 (B) It is greatest when  $r = R/2$ .  
 (C) It is directly proportional to  $r$  when  $r > R$ .  
 (D) It is directly proportional to  $r$  when  $r < R$ .  
 (E) It is directly proportional to  $r^2$ .

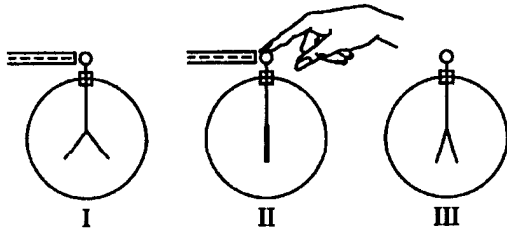

69. When a negatively charged rod is brought near, but does not touch, the initially uncharged electroscope shown above, the leaves spring apart (I). When the electroscope is then touched with a finger, the leaves collapse (II). When next the finger and finally the rod are removed, the leaves spring apart a second time (III). The charge on the leaves is  
 (A) positive in both I and III  
 (B) negative in both I and III  
 (C) positive in I, negative in III  
 (D) negative in I, positive in III  
 (E) impossible to determine in either I or III

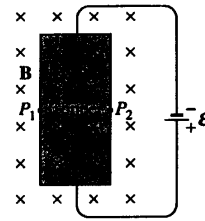

70. A sheet of copper in the plane of the page is connected to a battery as shown above, causing electrons to drift through the copper toward the bottom of the page. The copper sheet is in a magnetic field  $\mathbf{B}$  directed into the page.  $P_1$  and  $P_2$  are points at the edges of the strip. Which of the following statements is true?  
 (A)  $P_1$  is at a higher potential than  $P_2$ .  
 (B)  $P_2$  is at a higher potential than  $P_1$ .  
 (C)  $P_1$  and  $P_2$  are at equal positive potential.  
 (D)  $P_1$  and  $P_2$  are at equal negative potential.  
 (E) Current will cease to flow in the copper sheet.